

U.S. POSTAL SERVICE STANDARD MAILBOXES, CURBSIDE

1. SCOPE AND CLASSIFICATION

1.1 Scope - This standard covers all curbside mailboxes. Curbside mailboxes are defined as any design made to be served by a carrier from a vehicle on any city, rural or highway contract route. This standard is not applicable to mailboxes intended for door delivery service (see 6.1).

1.2 Classifications - Based on their size and design, curbside mailboxes are classified as either:

T - Traditional, Full or Limited Service (see 3.2.1 & Figure 1)

C - Contemporary, Full or Limited Service (see 3.2.2)

L - Locked, Full or Limited Service (see 3.2.3 & Figures 2 & 3)

1.3 Approved Models

1.3.1 Approved Models - Manufacturers whose mailboxes have been approved by the United States Postal Service (USPS) will be listed in the Postal Operations Manual (POM) and published in the Postal Bulletin.

1.3.2 Interested Manufacturers - Manufacturing standards and current information concerning the manufacture of curbside mailboxes may be obtained by writing to:

USPS, Information Platform
Delivery & Retail Operation Equipment
8403 Lee Highway
Merrifield, VA 22082-8101

2. APPLICABLE DOCUMENTS

2.1 Specifications and Standards - Except where specifically noted, the specifications set forth herein shall apply to all curbside mailbox designs.

2.2 Government Documents - The following documents of the latest issue are incorporated by reference as part of this standard.

United States Postal Service

POM Postal Operations Manual

Copies of the Postal Operations Manual can be obtained from the USPS New Jersey Material Distribution Center, 2 Brick Plant Road, South River, NJ 08877-9998.

2.3 Non-Government Documents - The following documents of the latest issue are incorporated by reference as part of this standard.

American Standards for Testing Materials (ASTM)

ASTM G85 Standard Practice for Modified Salt Spray (Fog) Testing

ASTM D968 Standard Test Methods for Abrasion Resistance of Organic Coatings by Falling Abrasive

Copies of the preceding documents can be obtained from the American Society for Testing and Materials, 100 Barr Harbor Drive, West Conshohocken, PA 19428-2959.

Underwriters Laboratories

UL 771 Night Depositories (Rain Test Only)

Copies of the preceding document can be obtained from Underwriters Laboratories Inc., 333 Pfingsten Road, Northbrook, IL 60062-2096

American Society for Quality

ANSI/ASQC Q9002-1994 Quality Systems - Model for Quality Assurance in Production, Installation, and Servicing

ANSI/ISO/ASQC Q10013-1995 Guidelines for Developing Quality Manuals

Copies of the preceding documents can be obtained from the American Society for Quality, PO Box 3066, Milwaukee, WI 53201-3066.

3. REQUIREMENTS

3.1 Quality - Mailbox manufacturers must ensure and be able to substantiate that units manufactured conform to the requirements of this specification.

3.1.1 Inspection - The Postal Service reserves the right to inspect units for conformance to this specification at any stage of manufacture. Inspection by the Postal Service does not relieve the manufacturer of the responsibility to provide performance that conforms to the requirements set forth in this specification. Prior to any visits, the Postal Service will provide a minimum notice of 30 business days. The Postal Service may, in its discretion, suspend the approval status of any manufacturer's model which is found to be out of conformance with approved drawings (see 5.2.2).

3.1.2 System - The manufacturer shall use a documented quality system acceptable to the Postal Service. As a minimum, the manufacturer's quality system shall include controls and record keeping in the following areas: (A quality system in compliance with ANSI/ASQC Q9002-1994 meets this requirement).

3.1.2.1 Inspection and testing;

3.1.2.2 Inspection, measuring, and test equipment;

3.1.2.3 Control of nonconforming products;

3.1.2.4 Document control; and

3.1.2.5 Corrective action.

3.1.3 System Evaluation - The Postal Service has the right to evaluate the acceptability and effectiveness of the manufacturer's quality system before approval and during tenure as approved source.

3.1.4 Records - All of the manufacturer's records pertaining to the approved product shall be kept for a minimum of three (3) years after shipment of product.

3.2 General Design - Mailboxes must meet regulations and requirements as stipulated by USPS collection and delivery, operation and policy (see 2.2). This includes carrier door operation as stated in 3.4, flag operation as stated in 3.7, in-coming mail openings and the retrieval of out-going mail. The opening style, design and size are determined by the manufacturer, however, the carrier must be able to deposit the customer's mail. Out-going mail of all designs must be able to be pulled straight out of the mailbox without interference from protrusions, hardware, etc. Mailboxes must be capable of passing the applicable testing requirements in 3.15. Mailboxes must not be made of any transparent, toxic, or flammable material (see 3.3). The mailbox must protect mail from potential water damage which may result from wet weather conditions see

section 3.15.3. Any advertising on a mailbox or its support is prohibited. Additional specific requirements follow.

3.2.1 Traditional Designs (Limited & Full Service) - Mailbox designs which conform to Figure 1 and meet capacity requirements specified in 3.15.1 will be classified as Traditional. Designs incorporating a carrier signal flag (see 3.7) will be classified as full service mailboxes. Designs with no flag will be classified as limited service (see 3.12). As specified in 3.5, a rear door is permitted to enable the customer to remove mail without standing in the street. The use of locks, locking devices or inserts is prohibited.

3.2.2 Contemporary Designs (Limited & Full Service) - Mailbox designs which do not conform to dome-rectangular shape of Traditional designs but meet capacity requirements specified in 3.15.1 while not exceeding maximum dimensions of Figure 1 will be classified as Contemporary. Designs incorporating a carrier signal flag (see 3.7) will be classified as full service mailboxes. Designs with no flag will be classified as limited service (see 3.12). Although the shape and design is less restrictive, Contemporary mailboxes must meet the same applicable functional requirements. Contemporary designs can also incorporate a rear door, as specified in 3.5, to enable the customer to remove mail without standing in the street. The use of locks, locking devices or inserts is prohibited.

3.2.3 Locked Designs - Mailbox designs which provide security for customer's in-coming mail will be classified as Locked mailboxes (see Figures 2 & 3). Although the shape and design is less restrictive, Locked mailboxes must meet the same applicable functional requirements. Designs having a slot for in-coming mail must be at least 1.75 inches high by 10 inches wide. If a slot has a protective flap it must operate inward to ensure mail can be inserted in horizontal manner without requiring any additional effort of carriers (see Figure 3). The slot must be positioned on the front side of the mailbox facing the street. In addition, the slot must be clearly visible and directly accessible by mail carriers. Any designs, which allow for out-going mail, must meet all applicable requirements of this standard.

3.2.3.1 Full Service - Locked mailbox designs of this class allow for both in-coming and out-going mail as depicted in Figure 2. It is preferred that both in-coming and out-going mail compartments be located behind a single carrier service door as shown in Figure 2. Alternate positioning of the in-coming mail compartment such as beneath or side-by-side with the out-going compartment is permitted provided that no additional carrier service is introduced.

3.2.3.2 Limited Service - Locked mailbox designs of this class only allow for in-coming mail as shown in Figure 3.

3.2.4 Mailbox Accessories - Decorative art and devices can be attached to the exterior of approved mailbox designs provided they do not interfere with mail delivery or present a safety hazard. Devices can also be mounted in the interior of approved mailboxes provided they do not cause the intended mailbox to fail capacity test described in 3.15.1 and do not interfere with mail delivery or present a safety hazard. Any advertising on a mailbox or its support is prohibited. Unrestricted spring-loaded devices and designs are prohibited. Auxiliary flags or devices used to signal the customer that the mail has arrived must operate automatically without requiring additional carrier effort.

3.3 Materials - Ferrous or nonferrous metal, wood (restrictions apply), plastic, or other materials may be used, as long as their thickness, form, mechanical properties, and chemical properties adequately meet the operational, structural, and performance requirements set forth in this standard. Materials used must not be toxic, flammable or transparent.

3.3.1 Mailbox Floor - The entire bottom area of all mailboxes where mail would rest shall be fabricated to prevent mail from damage due to condensation or moisture. Except for the internal mail compartment of locked style mailboxes, all designs must not present a lip or protrusion that would prevent the mail from being inserted or pulled straight out of the mailbox. The surface of the floor cannot be made of wood material. The floor shall be ribbed as shown in Figures 1, 2, and 3 or dimpled, embossed, or otherwise fabricated provided the resulting surface area (touching mail) does not exceed .25 square inch (per dimple/impression) and is minimum of .12 inch high on centers not exceeding 1 inch. A mat insert having a raised surface contour may be used for the internal mail compartment of locked style mailboxes only (see Figures 2 & 3).

3.3.2 Carrier Signal Flag - Cannot be made of wood. Plastic is the preferred material.

3.3.3 Door Handle - Cannot be made of wood. Plastic is the preferred material.

3.4 Carrier Service Door - There shall be only one carrier service door which must provide access for mail delivery and collection intended by the unit and meet USPS delivery operational requirements (see 2.2). The door must meet the applicable testing requirements specified in 3.15.2. The carrier service door must operate freely and solely by pulling outward and downward with a convenient handle or knob. The design of the door, including hinges and handles must provide protection against wind, rain, sleet, or snow (see 3.15.3). Door latches must hold the door closed but allow easy opening and closing requiring no more than 5 pounds of force. Action of the latch must be a positive mechanical one not relying solely on friction of the hinge parts. The door shall not be spring-loaded. Magnetic latches are acceptable provided adequate closure power is maintained during ambient conditions specified in 3.15.6 and applicable testing described in 3.15. It is preferred that by either tactile or by sound (i.e. "snap" or "click") carriers are alerted that door is properly shut. The door, once opened, must remain in the open position until the carrier pushes it closed. The door must rotate a minimum of 100 degrees when opened and it is preferred that the maximum rotation be limited to 120 degrees or less. When in a fully opened and rest position, the opening angle of the door cannot measure more than 180 degrees. No protrusions other than the handle/knob, door catch, alternate flag design, decorative features or markings are permitted on the carrier service door. Protrusions of any kind that reduce the usable volume within the mailbox when closed are not acceptable. See section 3.2.3 for carrier service door requirements for Locked mailbox designs.

3.4.1 Handle/Knob - The handle or knob shall have adequate accessibility to permit quickly grasping and pulling it with one hand (with or without gloves) to open the door. The handle or knob shall be located within the top 1/3 of the door. Various acceptable handle/knob designs with required dimensions are depicted in Figure 5. Other designs may be acceptable provided they allow enough finger clearance and surface area for carriers to grasp.

3.5 Rear Doors - Mailboxes may have a rear door, provided that it does not interfere with the normal delivery and collection operation provided by the carrier or require the carrier to perform any unusual operations. The rear door must not be susceptible to being forced open as a result of large mail items such as newspapers and parcels being inserted through the carrier door. The rear door must meet the applicable testing requirements specified in 3.15.

3.6 Locks - Locked mailbox designs shall have an effective means to ensure that in-coming mail is only accessible by the customer. The use of locks on Contemporary and Traditional mailbox designs is prohibited. Manufacturers must include the following statement in their instructions to customers:

IT IS IMPORTANT TO NOTE THAT IT IS NOT THE RESPONSIBILITY OF MAIL CARRIERS TO OPEN MAILBOXES THAT ARE LOCKED, ACCEPT KEYS FOR THIS PURPOSE, OR LOCK MAILBOXES AFTER DELIVERY OF THE MAIL.

3.7 Carrier Signal Flag - Traditional, Contemporary, and Locked mailbox designs classified as Full Service shall have a carrier signal flag. The flag design must be one of the approved concepts depicted in Figures 1, 2, and 4. As shown in each figure, the flag must be mounted on the right side when facing the mailbox from the front. The flag must not require a lift or more than 2 pounds of force to retract. Additionally, when actuated (signaling out-going mail) the flag must remain in position until retracted by the carrier. The color of the flag must be in accordance with requirements described in 3.10. The operating mechanism of the flag must not require lubrication and must continue to operate properly and positively (without binding or excessive free play) after being subjected to test described in 3.15. Optionally, the flag may incorporate a self-lowering feature that causes it to automatically retract when the carrier service door is opened provided no additional effort is required of the carrier. The self-lowering feature cannot present protrusions or attachments and must not interfere with delivery operations in any manner or present hazardous features as specified in 3.2.

3.8 Marking - The mailbox must bear two inscriptions on the carrier service door: "U.S. MAIL" in a minimum of .50 inch high letters and "Approved By The Postmaster General" in a minimum of .18 inch high letters. These inscriptions may be positioned beneath the in-coming mail slot for Limited Service Locked Mailboxes as shown in Figure 3. Markings must be permanent and may be accomplished by applying a decal, embossing on sheet metal, raised lettering on plastic, engraving on wood or other methods that are suitable for that particular unit. The manufacturer's name, address, date of manufacture (month and year), and model number or nomenclature must be legible and permanently marked or affixed on a panel (rear, backside of door, bottom or side interior near the carrier service door) of the mailbox that is readily accessible and not obscured.

3.8.1 Modified Mailbox Marking - Mailboxes that use previously approved units in their design must include marking stating the new manufacturer's name address, date of manufacture and model nomenclature in a permanent fashion and location as described above. Additionally, The "U.S. MAIL" and "Approved By The Postmaster General" marking shall be reapplied if it is obscured or obliterated by the new design.

3.9 Coatings and Finishes - Choice of coatings and finishes is optional, provided all requirements of this standard are met. All coatings and finishes must be free from flaking, peeling, cracking, crazing, blushing, and powdery surfaces. Coatings and finishes must be compatible with the mailbox materials. Accept for small decorative accents, mirror-like coatings or finishes are prohibited. The coating or finish must meet the applicable testing requirements described in 3.15.5.

3.10 Color - The color of the mailbox and flag must be in accordance with the following requirements. The mailbox may be any color. The carrier signal flag can be any color except any shade of green, brown, white, yellow or blue. The preferred flag color is fluorescent orange. Also, the flag color must present a clear contrast with predominant color of the mailbox.

3.11 Mounting - The mailbox shall be provided with means for convenient and locked mounting that meets all applicable requirements of the POM. The manufacturer may offer various types of mounting accessories such as a bracket, post or stand. Although the USPS does not regulate

the design of mounting accessories, it is pointed out that no part of them is permitted to project beyond the front of the mounted mailbox. Mounting accessories must not interfere with delivery operations as described in 3.2 or present hazardous features as described in 3.14. See section 6 for additional important information.

3.12 Instructions and Product Information

3.12.1 Assembly and Installation - A complete set of instructions for assembling and mounting the mailbox shall be furnished with each unit. The instructions must include the following conspicuous message:

CUSTOMERS ARE REQUIRED TO CONTACT THE LOCAL POST OFFICE BEFORE INSTALLING THE MAILBOX TO ENSURE ITS CORRECT PLACEMENT AND HEIGHT AT THE STREET. GENERALLY, MAILBOXES ARE INSTALLED AT A HEIGHT OF 41 - 45 in. FROM THE ROAD SURFACE TO INSIDE FLOOR OF THE MAILBOX OR POINT OF MAIL ENTRY (LOCKED DESIGNS) AND ARE SET BACK 6 - 8 in. FROM FRONT FACE OF CURB OR ROAD EDGE TO THE MAILBOX DOOR.

3.12.2 Limited Service Mailboxes - The following conspicuous note shall be included with each mailbox:

THIS IS A LIMITED SERVICE MAILBOX (WITHOUT FLAG) AND IT IS ONLY INTENDED FOR CUSTOMERS WHO DO NOT WANT POSTAL CARRIERS TO PICK-UP THEIR OUT-GOING MAIL. UNLESS POSTAL CARRIERS HAVE MAIL TO DELIVER THEY WILL NOT STOP AT LIMITED SERVICE MAILBOXES.

3.13 Newspaper Receptacles - A receptacle for the delivery of newspapers may be attached to the post of a curbside mailbox provided no part of the receptacle interferes with the delivery of mail, obstructs the view of the flag, or presents a hazard to the carrier or the carrier's vehicle. The receptacle must not extend beyond the front of the box when the door is closed. No advertising may be displayed on the outside of the receptacle, except the name of the publication.

3.14 Workmanship - The mailbox shall be properly assembled and utilize the best commercial practice workmanship standards in the fabrication of all components and assemblies. All movable parts shall fit and operate properly with no unintended catch or binding points. The unit must be free from harmful projections or other hazardous devices. The unit must not have any sharp edges, sharp corners, burrs or other features (on any surfaces) that may be hazardous to carriers/customers, or that may interfere with delivery operations as described in 3.2 (General Design).

3.15 Testing Requirements - Mailboxes will be subjected to all applicable testing described herein (specific requirements follow). A mailbox that fails to pass any test will be rejected. Testing will be conducted in sequence as listed herein and in Table III.

3.15.1 Capacity - Traditional and Contemporary designs must meet minimum capacity requirements tested by insertion and removal of a standard test gauge which measures 18.50" long x 5.00" wide x 6.00" high. The test gauge is inserted with its 6.00" dimension aligned in the vertical axis (perpendicular to the mailbox floor). The gauge must be capable of easy insertion and removal; and while inserted, allow for the door(s) to be completely closed without interference. The capacity of Locked designs, which have slots, chutes or similar features, will be tested and approved based upon whether standard USPS mail sizes (see Table I) can be easily inserted through the mail slot or opening. Retrieval of

this mail from the locked compartment shall be equally as easy.

TABLE I
Standard Mail (Locked Designs)

Standard Mail (Locked Designs)	
Description	Size(L x H x Thk)
Express & Priority Mail Envelopes	12 1/2" x 9 1/2" x 1/2"
Priority Mail Box	8 5/8" x 5 3/8" x 1 5/8"

3.15.2 Operational Requirements - Carrier service doors, auxiliary doors, door catches/mechanisms, carrier signal flags and applicable accessory devices must be capable of operating 7,500 normal operating cycles (1 cycle = open/close) at room temperature, continuously and correctly, with out any failures such as breakage of parts. Testing may be performed either manually or by means of an automated mechanically driven test fixture which essentially mimics a manual operation. This test is applicable to all mailbox designs.

3.15.3 Water-Tightness - A rain test in accordance with UL 771, section 47.7 shall be performed to determine a mailbox's ability to protect mail from water. The rain test shall be operated for a period of 15 minutes for each side. At the conclusion of the test, the outside of the unit is wiped dry and all doors are opened. The inside of the compartment must contain no water other than that produced by high moisture condensation. This test is applicable to all mailbox designs.

3.15.4 Salt Spray Resistance - A salt spray test shall be conducted in accordance with method A5 of ASTM G85, Standard Practice for Modified Salt Spray (Fog) Testing. The salt test shall be operated for 25 continuous cycles with each cycle consisting of 1-hour fog and 1-hour dry-off. The mailbox shall be tested in a finished condition, including all protective coating, paint, and mounting hardware and shall be thoroughly washed when submitted to remove all oil, grease, and other nonpermanent coatings. No part of the mailbox may show finish corrosion, blistering or peeling, or other destructive reaction upon conclusion of test. Corrosion is defined as any form of property change such as rust, oxidation, color changes, perforation, accelerated erosion, or disintegration. The build-up of salt deposits upon the surface shall not be cause for rejection. However, any corrosion, paint blistering, or paint peeling is cause for rejection. This test is primarily applicable to ferrous metal mailbox designs. It is also valid for mailboxes designs made of plastic, wood, or other materials which use any metal hardware.

3.15.5 Abrasion Resistance - The Mailbox's coating/finish shall be tested for resistance to abrasion in accordance with method A of ASTM D968. The rate of sand flow shall be 2 liters of sand in 22 +3 seconds. The mailbox will have failed the sand abrasion test if less than 15 liters of sand penetrates its coating or if less than 75 liters of sand penetrates its plating. This test is applicable to metal mailbox designs only.

3.15.6 Temperature Stress Test - The mailbox under test shall be placed in a cold chamber at -65 Fahrenheit for 24 hours. The chamber shall first be stabilized at the test temperature. After remaining in the -65 environment for the 24-hour period, the unit shall be quickly removed from the cold chamber into room ambient and tested for normal operation. The removal from the chamber and the testing for normal operation shall be

accomplished in less than 3 minutes. The room ambient shall be between 65 and 75 Fahrenheit. Normal operation is defined as operation required and defined by this document. The unit under test shall undergo a similar temperature test, as described above, at a temperature of 140 Fahrenheit. This test is applicable to all mailbox designs.

3.15.7 Structural Rigidity Requirements - Forces of specified magnitude (see Table II) shall be slowly applied at specific points on the mailbox under test (see Figure 6). These forces shall be held for a minimum of one minute and then released. After their release, the deformation caused by the forces shall be measured. If the deformation exceeds the limit specified in Table II, the mailbox under test has failed to meet the structural rigidity requirement. The doors shall remain closed for test positions 1 through 6. The application of the forces at positions 1 and 2 shall be applied with the mailbox in its normal upright position, supported by a horizontal board. The application of the forces at positions 3, 4, and 5 shall be applied with the mailbox lying on its side (flag side down). The mailbox shall be supported, on the under side, by a flat board that is relieved in the immediate area of the flag mechanism. The application of force at position 6 (Traditional style flags only) shall be applied with the mailbox lying on its side (flag side up). The application of force at position 6 shall be repeated at the top of the flag with the mailbox in its normal upright position. If visible cracks, in the material, have developed as a result of the testing, the mailbox under test has failed to meet the structural rigidity requirement. At the conclusion of the Structural Rigidity testing, if the mailbox under test fails to operate normally, as defined by this document, the mailbox under test has failed to meet the structural Rigidity requirement. This test is applicable to all mailbox designs.

TABLE II
Permanent Deformation Limits

Permanent Deformation Limits

Position	Deformation(inches)	Load(pounds)
1	1/8	200
2	1/8	200
3	1/8	50
4	1/8	50
5	1/8	100
6	1/2	2

3.15.8 Impact Test - Refer to the Figure 6 for load positions. Precondition the mailbox for 4 hours at -20 Fahrenheit. The following testing shall be performed within 3 minutes of removing the mailbox from the temperature chamber. At both load positions 3 and 4, with the mailbox lying on its side (flag side down) with the door(s) closed, apply an impact load equivalent to a 10-pound weight dropped from a height of 3-feet above the mailbox surface onto a bolster plate having a surface not larger than 2 inches by 2 inches. The mailbox shall be supported, on the underside, by a flat board that is relieved in the immediate area of the flag mechanism. If any noticeable perforation, occurrence of sharp edges, or cracking of the material, either inside or outside the mailbox, develops as a result of the impact; or if the door becomes inoperable or fails to close normally, the mailbox under test has failed to meet the impact resistance requirement. This test is applicable to all mailbox designs.

4. APPLICATION REQUIREMENTS

4.1 Application Requirements - Requests for application materials, and all other correspondence and inquiries, shall be directed to the address in 1.3.2. The application process consists of:

4.1.1 Preliminary Review - Manufacturers must first satisfy requirements of a preliminary review prior to submitting any sample mailboxes or accessories. The preliminary review consists of a review of the manufacturer's conceptual design drawings. Computer generated drawings are preferred, but hand drawn sketches are acceptable provided they clearly depict the overall shape and interior size of the proposed mailbox design. Drawings must also include details on design of applicable features such as the carrier service door, latch, handle, flag, floor, and slot. In addition to drawings, proposed accessories shall show or describe intended function. If drawings show that the proposed mailbox design appears to comply with the requirements of this standard, manufacturers will be notified in writing and may then continue with the application requirements described in 4.1.2. Do NOT submit any sample mailboxes to the USPS prior to complying with the requirements of 4.1.2. Notification that a manufacturer's drawings satisfy the requirements of the preliminary review does NOT constitute USPS approval of a design, and shall NOT be relied upon as an assurance that a design will be approved.

4.1.2 Testing - Upon receiving written notification from the USPS that their design satisfies requirements of the preliminary review, manufacturers shall at their own expense submit one sample of their mailbox or accessory to an independent laboratory for testing along with a copy the preliminary review letter from the USPS. See Appendix A for a list of USPS approved independent test labs. Manufacturers with more than one unique model shall have each one tested independently. Models which are generally of the same size, shape, and material of previously approved designs but only have different decorative features (i.e. color scheme and surface contours) are not considered unique and do not require any testing. Manufacturers seeking approval of models that are not unique shall submit documentation for each model in accordance with section 4.1.3.2. This documentation will be reviewed and the proposed model will either be approved or disapproved (see section 5). The USPS may request manufacturer to submit one sample of the proposed model.

4.1.3 Final Review - Manufacturers shall submit one sample mailbox or accessory to the USPS for final review and approval. The sample shall be accompanied with a certificate of compliance and a copy of the laboratory test results (see 4.1.3.3). Mailboxes submitted to the USPS (see 1.3.2) for final evaluation must be identical in every way with the mailboxes to be marketed, and must be marked as specified in 3.8. Manufacturers may be subject to a verification of their quality system prior to approval. This may consist of a review of the manufacturer's quality manual (see 4.1.3.4) and an on-site quality system evaluation (see 3.1).

4.1.3.1 Instructions - Submit a copy of the instructions conforming to 3.12 including the statement concerning locks in 3.6.

4.1.3.2 Documentation - The unit submitted for approval shall be accompanied by one complete set of manufacturing drawings consisting of black on white prints (blueprints or sepia are unacceptable). The drawings shall be dated and signed by a manufacturer's representative(s). The drawings must completely document and represent the design of the unit tested. The drawings must include sufficient details to allow the USPS to inspect all materials, construction methods, processes, coatings, treatments, finishes (including paint types and colors), control specifications, parts and assemblies used in the construction of the unit. Additionally, the drawings must fully describe any purchased materials, components

and hardware including their respective finishes. The USPS may request individual piece parts to verify drawings.

4.1.3.3 Certification of Compliance & Test Results - Manufacturers shall furnish a written certificate of compliance indicating that their design fully complies with the requirements of this specification. In addition, the manufacturer shall submit the lab's original report which clearly shows results of each test conducted (see Table III). The manufacturer bears all responsibility for their unit(s) meeting these requirements and the USPS reserves the right to retest any and all units submitted including those which are available to the general public.

TABLE III
Test Requirements

Test Requirements			
Test	Requirement	Reference	Applicable Document
Capacity	Insertion of test gauge	3.15.1	
Operational Requirements	7,500 cycles	3.15.2	
Water-Tightness	No appreciable moisture	3.15.3	UL 771, Section 47.7
Salt Spray Resistance	25 cycles	3.15.4	ASTM G85
Abrasion Resistance	75 liters	3.15.5	ASTM D968
Temperature Stress Test	Shall function between - 65 F and 140 F	3.15.6	
Structural Rigidity Requirements	Refer to Table I for loads and points, maximum 1/8 inch permanent deformation	3.15.7	
Impact Test	10 lbs. dropped from 3 feet	3.15.8	

4.1.3.4 Quality Assurance Manual - Manufacturer shall submit its quality policy manual. The manual should be structured in accordance with ISO 10013 and with the requirements of ISO 9002.

5. APPROVAL OR DISAPPROVAL

5.1 Disapproval - Written notification, including reasons for disapproval, will be sent to the manufacturer within 30 days of completion of the final review of all submitted units. All correspondence and inquiries shall be directed to the address listed in 1.3.2.

5.1.1 Disapproved Mailboxes - Mailboxes disapproved will be disposed of in 30 calendar days from the date of the written notification of disapproval or returned to the manufacturer, if requested, provided the manufacturer pays shipping costs.

5.2 Approval - One set of manufacturing drawings with written notification of approval will be returned to the manufacturer. The drawings will be stamped and identified as representing each unit.

5.2.1 Approved Mailboxes - Mailboxes that are approved will be retained by the USPS.

5.2.2 Rescission - Manufacturer's production units shall be constructed in accordance with the identified (stamped) drawings and provisions of this specification and be of the same materials, construction, coating, workmanship, finish, etc. as the approved units. Within 60 days upon sale of their approved mailbox to the public, manufacturers shall submit one production unit to the USPS office listed in 1.3.2. The USPS reserves the right at any time to examine and retest units obtained either in the general marketplace or from the manufacturer. If the USPS determines that a mailbox model is not in compliance with this standard or is out of conformance with approved drawings, the USPS may, in its discretion, rescind approval of the mailbox model as follows:

5.2.2.1 The USPS shall provide written notification to the manufacturer that a mailbox model is not in compliance with this standard or is out of conformance with approved drawings. Notification shall include specific reasons the mailbox model is noncompliant or out of conformance, and shall be sent via registered mail.

5.2.2.2 If the USPS determines that the noncompliance or nonconformity constitutes a danger to the health or safety of postal carriers, the USPS may, in its discretion, immediately rescind approval of the mailbox model. In addition, the USPS may, in its discretion, order that production of the mailbox model cease immediately, and that any existing inventory not be sold for use as curbside mailboxes in the United States of America.

5.2.2.3 In all cases of noncompliance or nonconformity other than those determined to constitute a danger to the health or safety of postal carriers, the manufacturer shall confer with the USPS and shall submit one sample of the corrected mailbox to the USPS for approval no later than 45 calendar days after receipt of the notification described in 5.2.2.1.

5.2.2.4 The USPS shall respond to the manufacturer in writing, via registered mail, no later than 30 calendar days after receipt of the sample corrected mailbox with a determination of whether the manufacturer's submission is accepted or rejected and with specific reasons for the determination.

5.2.2.5 If the USPS rejects the corrected mailbox, the manufacturer may submit a second sample of the corrected mailbox to the USPS for approval no later than 45 calendar days after receipt of the notification described in 5.2.2.4.

5.2.2.6 The USPS shall respond to the manufacturer in writing no later than 30 calendar days after receipt of the second sample corrected mailbox with a determination of whether the manufacturer's submission is accepted or rejected and with specific reasons for the determination. If the second submission is rejected, the USPS may, in its discretion, rescind approval of the mailbox model. In addition, the USPS may, in its discretion, order that production of the mailbox model cease immediately, and that any existing inventory not be sold for use as curbside

mailboxes in the United States of America. If the USPS rescinds approval, the manufacturer is not prohibited from applying for a new approval pursuant to the provisions of Section 4.

5.2.3 Revisions, Product or Drawings - Changes which affect the form, fit, and/or function (i.e. dimensions, material, finish) of approved products or drawings shall not be made without written approval from the USPS. Any proposed changes shall be submitted with the affected documentation, reflecting the changes (including a notation in the revision area) and a written explanation of the changes. One unit, incorporating the changes, may be required to be resubmitted for testing and evaluation for approval.

5.2.3.1 Revisions, Manufacturer Structure - If any substantive part of the approved manufacturer's structure change from what existed when the manufacturer became approved, the manufacturer shall notify the USPS and may be subject to a re-evaluation of product or quality system. Examples of substantive structural changes are: change in executive or quality management; major change in quality policy or procedures; relocation of manufacturing facilities; major equipment or manufacturing process change (e.g., outsourcing vs. in-plant fabrication); etc. Notification of such changes will be to the address in paragraph 1.3.2.

5.2.4 Product Brochure - Within 60 days upon sale to public, manufacturers shall submit one copy of their product(s) brochure(s) representing approved mailbox design(s) to the address listed in 1.3.2 and to:

USPS
Delivery Policy & Programs
475 L'Enfant Plaza, Rm 7142
Washington, DC 20260-0004

6. NOTES

6.1 Mailboxes intended to be used in delivery to customer's doors are not currently "approved" by the United States Postal Service as referenced in this standard. However, it is recommended that these boxes conform to the intentions of this specification, particularly the safety of the carrier/customer and the protection of the mail. Local postmaster shall be contacted prior to installation and use of any door mailbox.

6.2 The United States Postal Service does not approve mailbox posts or regulate mounting of mailboxes other than the requirements specified in sections 3.11 and 3.12. Please note that mailbox posts are often subject to local restrictions, state laws and federal highway regulations. Further information may be obtained from:

American Association of State Highway & Transportation Officials
444 N. Capitol St. NW, Suite 249
Washington, D.C. 20001-1512

Federal Highway Administration
Office of Highway Safety, HHS-10

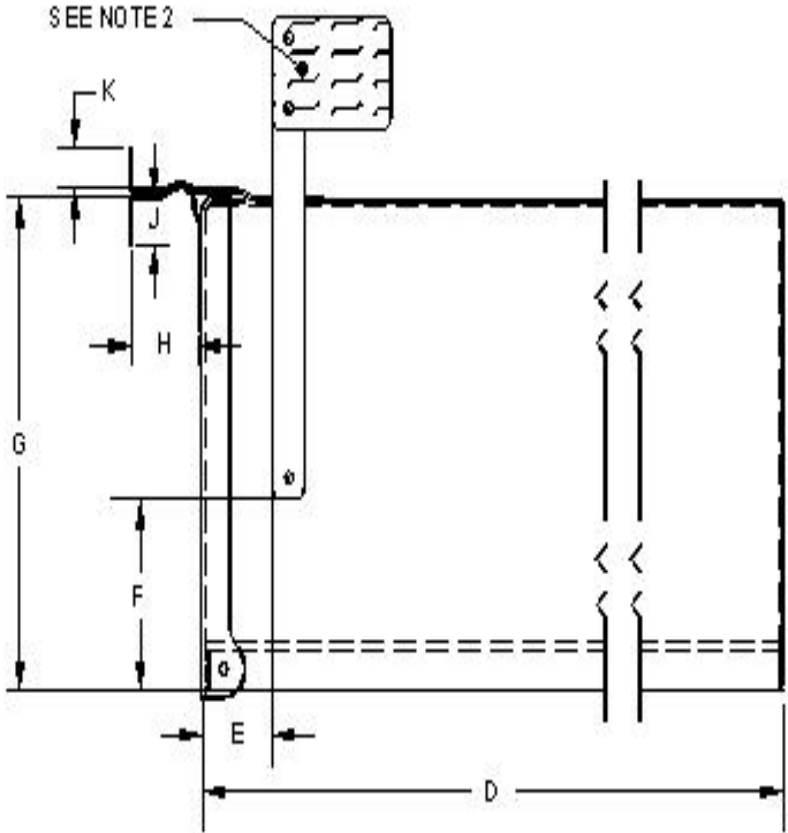
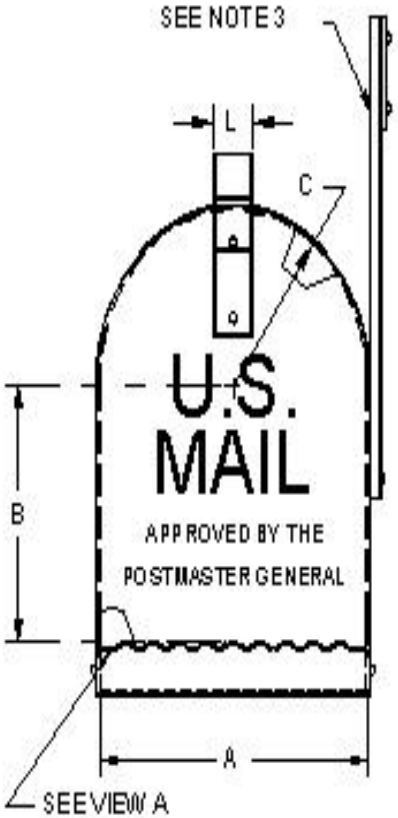

DIM	MIN	MAX	DIM	MIN	MAX
A	6.25	11.00	G	6.00	15.00
B	4.50	8.25	H	1.00	2.12
C	3.12R	5.50R	J	1.00	2.00
D	18.96	22.81	K	.50	.87
E	-	2.00	L	.87	1.25
F	3.75	8.50			

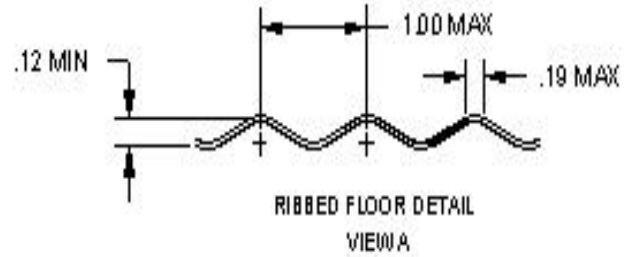

NOTES:

UNITS: INCHES

- 1.) DIMENSIONS A, B, C, & D ARE INTERIOR.
- 2.) SIGNAL PORTION OF FLAG (4 SQ. IN. MIN) ABOVE TOP SURFACE OF BOX.
- 3.) NO SHARP EDGES.

TRADITIONAL MAILBOX
FIGURE 1 - [Long Description](#)

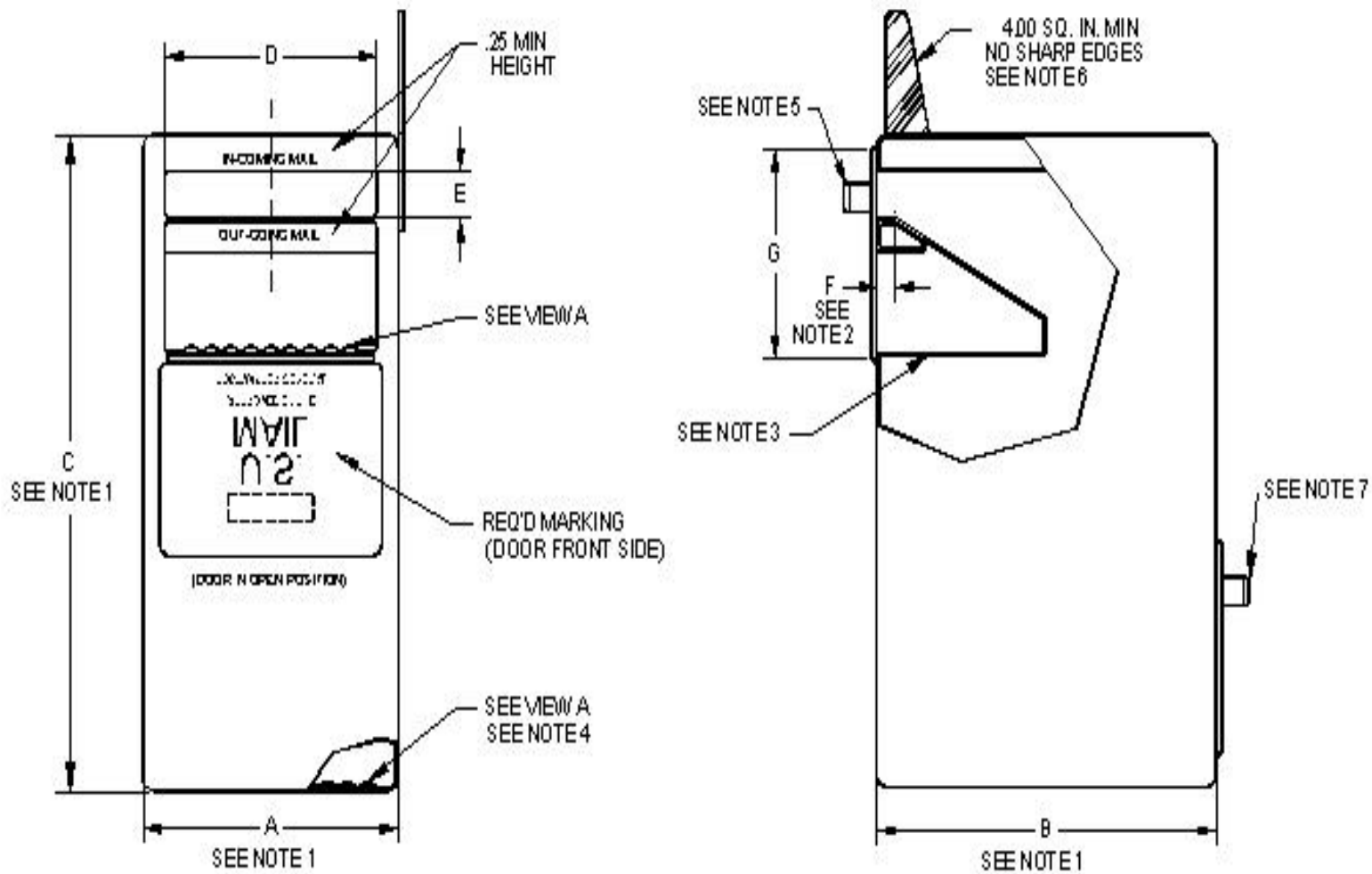

NOTES:

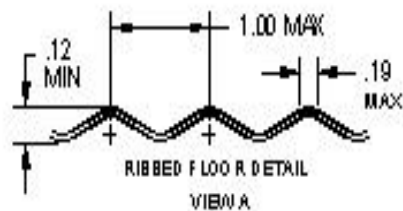

DIM	MIN	MAX
A	-	-
B	-	-
C	-	-
D	10.00	-
E	1.75	-
F	-	2.00
G	-	15.00

UNITS: INCHES

- 1) DIMENSIONS A, B, & C DETERMINED BY MANUFACTURER, BUT MUST PASS CAPACITY TEST.
- 2) MAXIMUM SET-BACK FOR R-SLOT IS 2.00" WHEN MEASURED FROM FRONT WALL OF THE MAILBOX.
- 3) COMPARTMENT MUST BE LARGE ENOUGH TO ACCOMMODATE SEVERAL 9.50" L X 4.25" H LETTERS. LETTERS CAN BE PLACED ON BACKSIDE OF THE CARRIER SERVICE DOOR, ELIMINATING NEED FOR AN OUT-GOING MAIL COMPARTMENT PROVIDED MAIL DOES NOT FALL OUT WHEN DOOR IS OPENED.
- 4) A MAT INSERT AND OTHER FORMING TECHNIQUES ARE ACCEPTABLE.
- 5) HANDLE SHALL BE POSITIONED WITHIN TOP 1/3 OF CARRIER SERVICE DOOR AND PROVIDE 1.00" MINIMUM FINGER CLEARANCE.
- 6) FRONT EDGE OF FLAG MUST NOT BE SET BACK MORE THAN 2.00" WHEN MEASURED FROM FRONT WALL OF MAILBOX.
- 7) OPTIMAL LOCATION OF CUSTOMER ACCESS DOOR.

LOCKED MAILBOX (FULL SERVICE)
 FIGURE 2 - [Long Description](#)

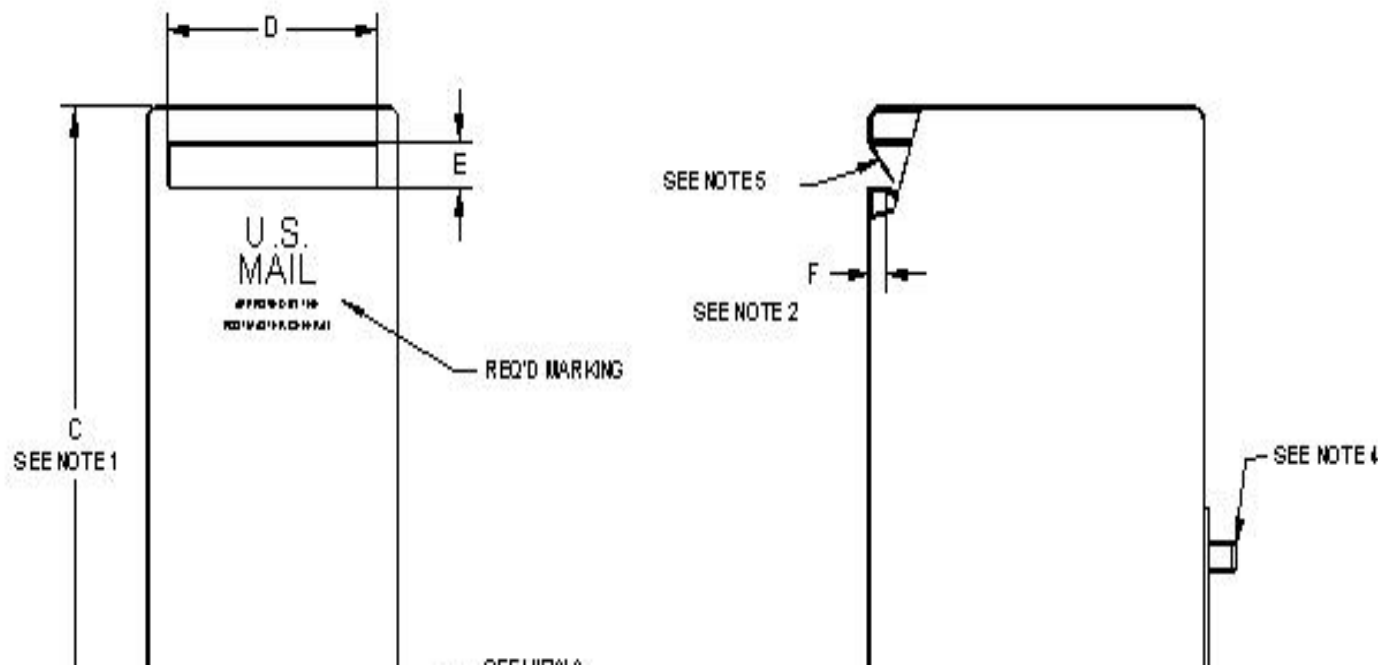

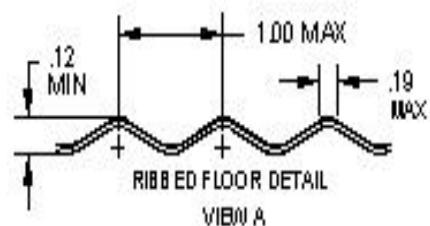
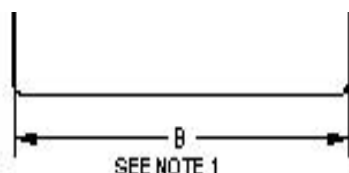
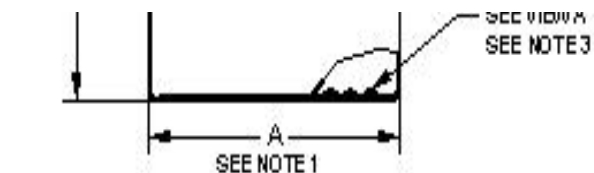

DIM	MIN	MAX
A	-	-
B	-	-
C	-	-
D	10.00	-
E	1.75	-
F	-	2.00

UNITS: INCHES

NOTES:

- 1) DIMENSIONS A, B, & C DETERMINED BY MANUFACTURER.
- 2) MAXIMUM SET-BACK FOR SLOT IS 2.00" FROM FRONT WALL OF THE MAILBOX.
- 3) A MAT INSERT AND OTHER FORMING TECHNIQUES ARE ACCEPTABLE.
- 4) OPTIONAL LOCATION OF CUSTOMER ACCESS DOOR.
- 5) IF SLOT HAS A PROTECTIVE FLAP IT MUST OPERATE INWARD. IT IS PREFERRED THAT SLOT BE LOCATED BEHIND A CARRIER SERVICE DOOR.

LOCKED MAILBOX (LIMITED SERVICE)

FIGURE 3 - [Long Description](#)

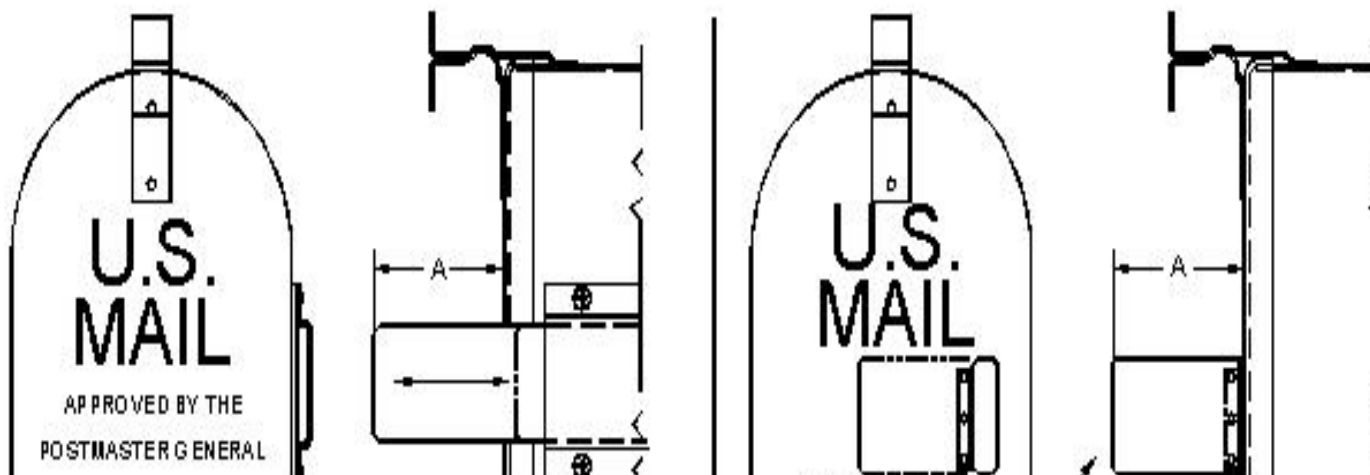

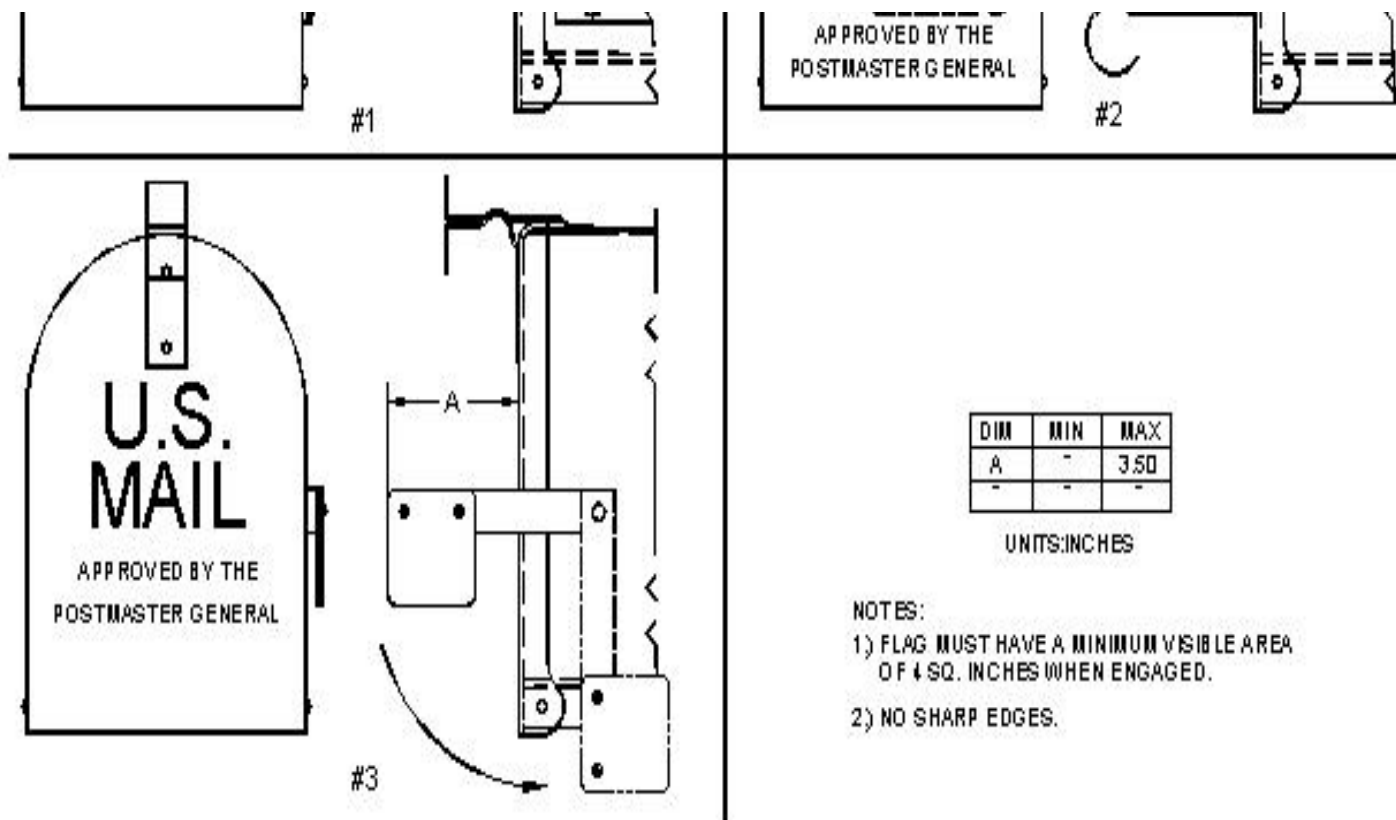

DIM	MIN	MAX
A	-	3.50
-	-	-

UNITS: INCHES

NOTES:

- 1) FLAG MUST HAVE A MINIMUM VISIBLE AREA OF 4 SQ. INCHES WHEN ENGAGED.
- 2) NO SHARP EDGES.

ALTERNATIVE FLAG DESIGNS
 FIGURE 4 - [Long Description](#)

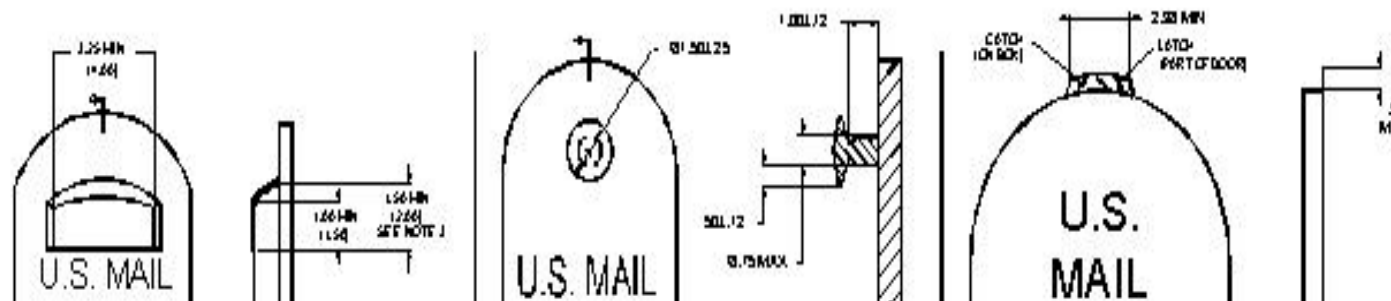

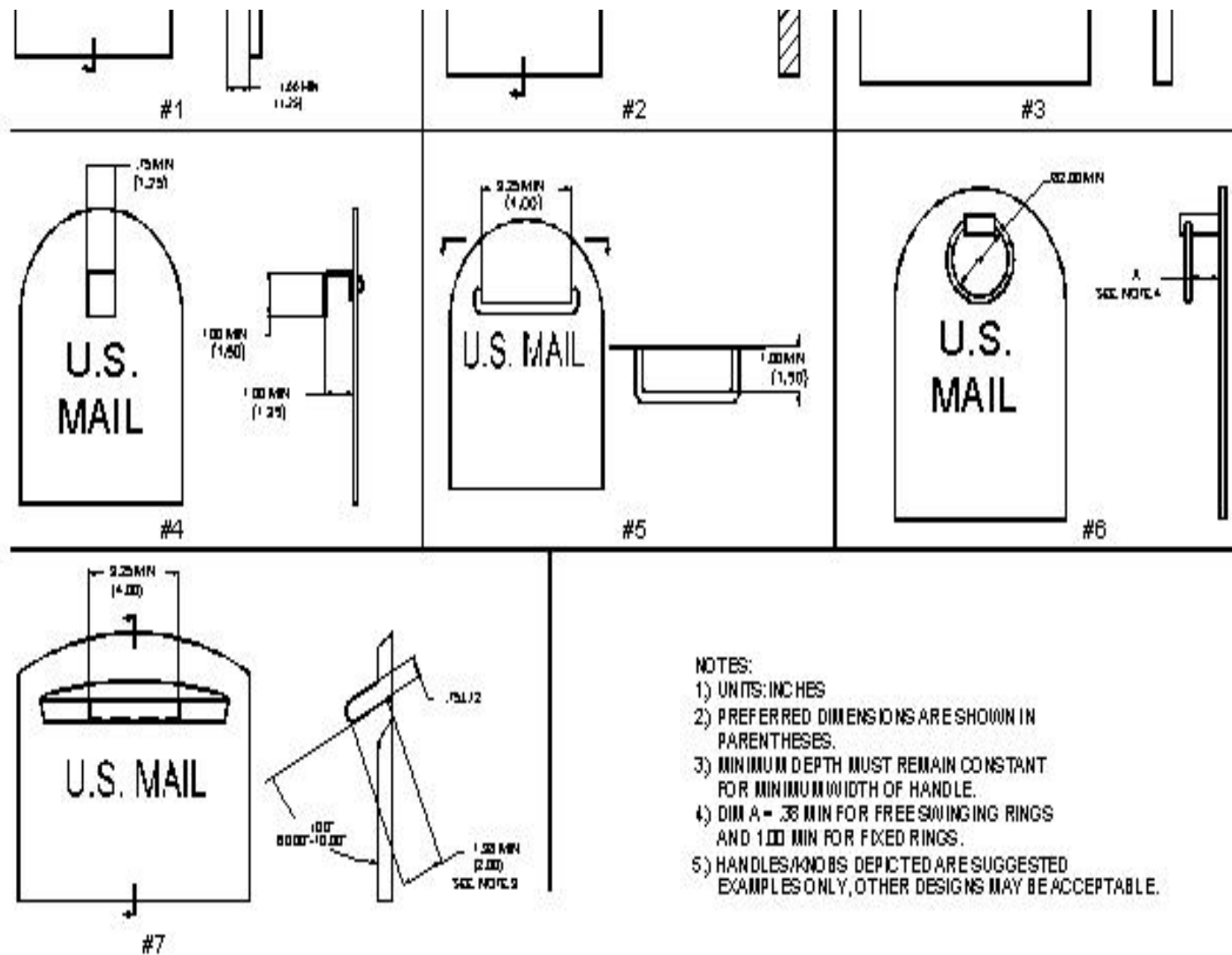

- NOTES:
- 1) UNITS: INCHES
 - 2) PREFERRED DIMENSIONS ARE SHOWN IN PARENTHESES.
 - 3) MINIMUM DEPTH MUST REMAIN CONSTANT FOR MINIMUM WIDTH OF HANDLE.
 - 4) DIM A = .38 MIN FOR FREE SWINGING RINGS AND 1.00 MIN FOR FIXED RINGS.
 - 5) HANDLES/KNOBS DEPICTED ARE SUGGESTED EXAMPLES ONLY, OTHER DESIGNS MAY BE ACCEPTABLE.

HANDLE/KNOB DESIGNS
 FIGURE 5 - [Long Description](#)

BOLSTER PLATE
 3 IN X 3 IN

— POSITION #1

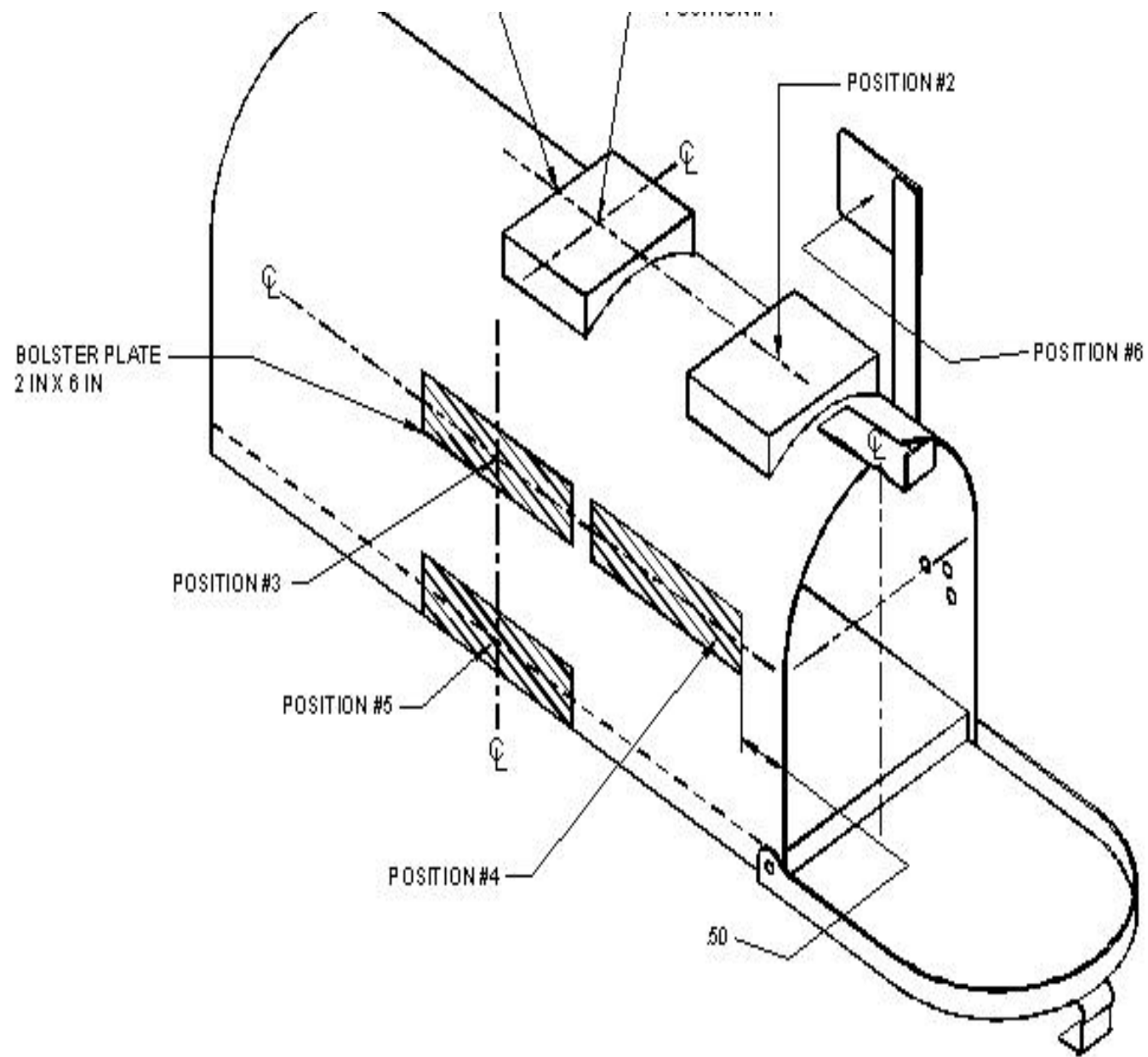

DIRECTION OF LOADS
 FIGURE 6 - [Long Description](#)

USPS APPROVED INDEPENDENT TEST LABORATORIES

1. ACTS Test Labs
Contact: Dennis Maclaughlin
Phone: 716-505-3547 Fax: 716-505-3301
100 Northpointe Parkway
Buffalo, NY14228-1884
2. The Coatings Lab
Contact: Tom Schwerdt
Phone: 713-981-9368 Fax: 713-776-9634
10175 Harwin Drive, Suite 110
Houston, TX 77036
3. Ithaca Materials Research & Testing, Inc. (IMR)
Contact: Jeff Zerilli, Vice President
Phone: 607-533-7000
Lansing Business and Technology Park
31 Woodsedge Drive
Lansing, NY 14882
4. Independent Test Laboratories, Inc.
Contact: Robert Bouvier
Phone: 800-962-Test Fax: 714-641-3836
1127B Baker Street
Costa Mesa, CA 92626
5. Environ Labs L.L.C.
Contact: Chuck Mapes
Phone: 1-800-826-3710, Fax: 612-888-6345
9725 Girard Ave S.
Minneapolis, MN 55431
6. Midwest Testing Laboratories, Inc.
Contact: Cherie Ulatowski
Phone: 248-689-9262, Fax: 248-689-7637
1072 Wheaton

Troy, MI 48083

Note: Additional test laboratories may be added provided they satisfy USPS certification criteria. Interested laboratories should contact:
USPS, Engineering
Test Evaluation & Quality
8403 Lee Highway
Merrifield, VA 22082-8101

The term 'preferred' as used throughout this document in conjunction with any requirement implies that compliance is desired but not mandatory.